



Visit our homepage
for additional support
parker.com/pmde

MSG30-5520-M1/UK

Service/ Spare Parts Manual Series F12-152, -162, -182

Effective: March, 2023
Supersedes: February, 2022



ENGINEERING YOUR SUCCESS.

List of contents	Page
General information.....	3
Specifications.....	4
Disassembling.....	5
Assembling.....	9
Test procedure.....	17
Splitview.....	18
Parts specification.....	19
Spare Parts.....	20
Tools.....	21

Conversion factors

1 kg	=	2.2046 lb
1 N	=	0.22481 lbf
1 bar	=	14.504 psi
1 l	=	0.21997 UK gallon
1 l	=	0.26417 US gallon
1 cm ³	=	0.061024 in ³
1 m	=	3.2808 feet
1 mm	=	0.03937 in
9/5 °C + 32	=	°F

General information

F12 is bent axis, fixed displacement heavy-duty motor/pump series. They can be used in numerous applications in both open and closed loop circuits.

Series F12 conforms to current ISO and SAE mounting flange and shaft end configurations.

Frame sizes: F12-152, -162, -182

Thanks to the unique spherical piston design, F12 motors can be used at unusually high shaft speeds. Operating pressures to 480 bar provides for the high output power capability.

The 40° angle between shaft and cylinder barrel allows for a very compact, lightweight motor/pump.

The laminated piston ring offers important advantages such as low internal leakage and thermal shock resistance.

The F12 motors produce very high torque at start-up as well as at low speeds. Our unique timing gear design synchronizes shaft and cylinder barrel, making the F12 very tolerant to high 'G' forces and torsional vibrations.

Heavy duty roller bearings permit substantial external axial and radial shaft loads.

The F12's have a simple and straightforward design with very few moving parts, making them very reliable motors/pumps.

The unique piston locking, timing gear and bearing set-up as well as the limited number of parts add up to a very robust design with long service life and, above all, proven reliability.

F12 cross section

1. End cap
2. Valve plate
3. Cylinder barrel
4. Piston with piston ring
5. Synchronisation Timing gear
6. Tapered roller bearing
7. Bearing housing
8. Shaft seal
9. Output/input shaft

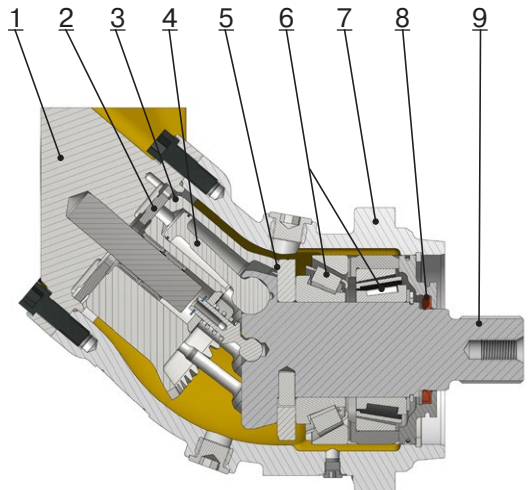

Frame size	F12-152	F12-162	F12-182
Displacement (cm ³ /rev)	149,8	163,1	179,8
Operating Pressure			
max intermittent ¹⁾ (bar)	480	480	480
max continuous (bar)	420	420	420
Motor operating speed			
max intermittent ¹⁾ (rpm)	4000	4000	4000
max continuous (rpm)	3700	3700	3700
min continuous (rpm)	50	50	50
Max pump selfpriming speed²⁾			
L or R function; max (rpm)	-	-	-
Motor input flow			
max intermittent ¹⁾ (l/min)	608	648	728
max continuous (l/min)	547	583	655
Main circuit temp.³⁾			
max (°C)	115	115	115
min (°C)	-40	-40	-40
Mass moment of inertia			
(x10 ⁻³) (kg m ²)	21	21	21
Weight			
(kg)	40	40	40
Theoretical torque at 100 bar (Nm)	238	260	286

¹⁾ Intermittent: max 6 seconds in any one minute.

²⁾ Selfpriming speed valid at sea level.

³⁾ See also below, operating temperature.

Operating temperature

NOTE: The temperature should be measured at the utilized drain port.

Continuous operation may require case flushing in order to meet the viscosity and temperature limitations.

For further information we refer to: Catalogue MSG30-8249/UK

Disassembling

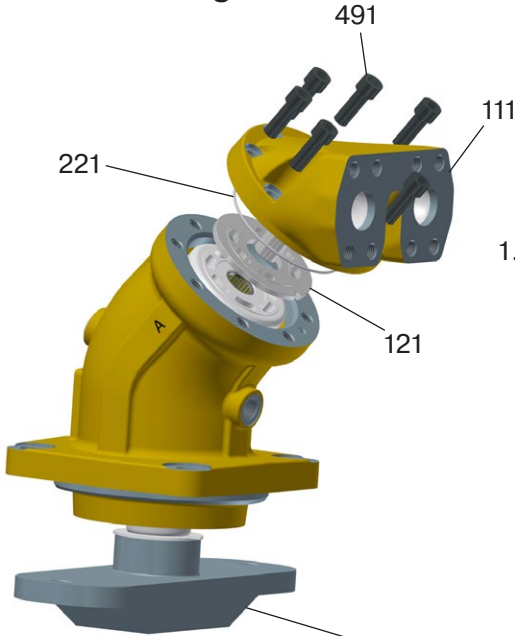

1. Fasten the fixture in a vise and place the motor in the fixture. Loosen the bolts (item 491). Carefully remove the end cap (item 110) and the O-ring (item 221). Make sure the valve plate (item 121) don't fall out.

See page 21, item 1, 7 and 8

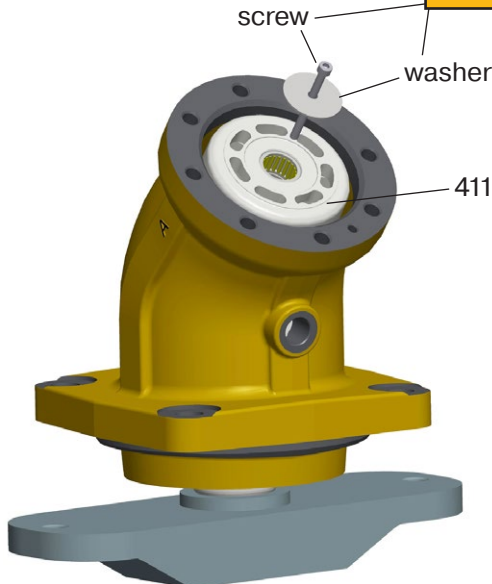

2. Fasten screw and washer to secure that the cylinder barrel (item 411) stays in correct position. There is a thread in the barrel support, item 430 (see page 18).

Disassembling

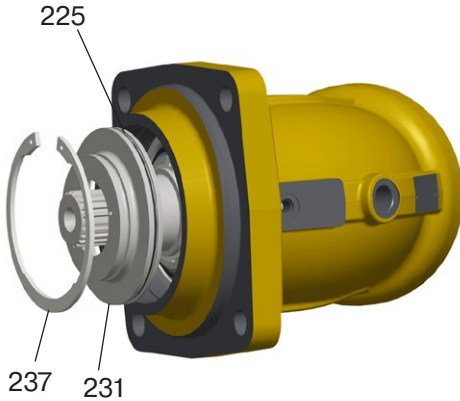

3. Place the motor on the side.
Disassemble the retaining ring (item 237), remove the shaft seal carrier (item 231) and the O-ring (item 225).

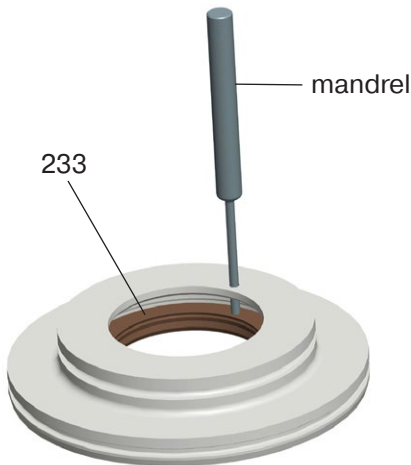

4. Use a mandrel and tap the shaft seal (item 233) out with a hammer. Make sure the O-ring (item 225) is removed (see picture 3 above).

Disassembling

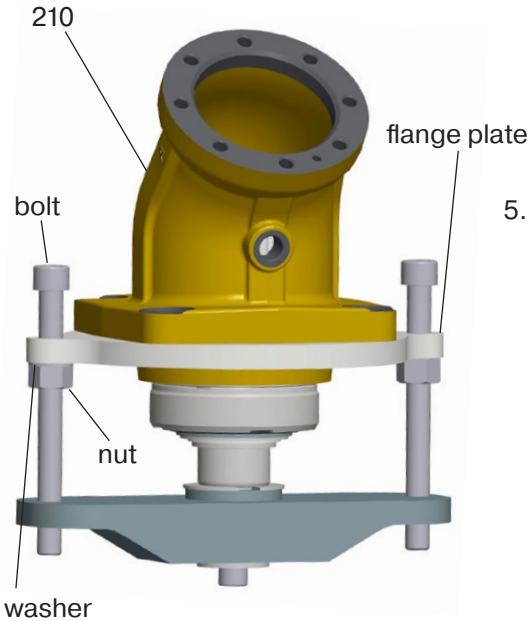

5. Add the flange plate to the fixture with bolts, washers and nuts.
Fit screw and washer so the motor is secured in the fixture.
Disassemble the bearing housing (item 210) by using the fixture as a puller. Screw the nuts alternately until the bearing housing is loose.

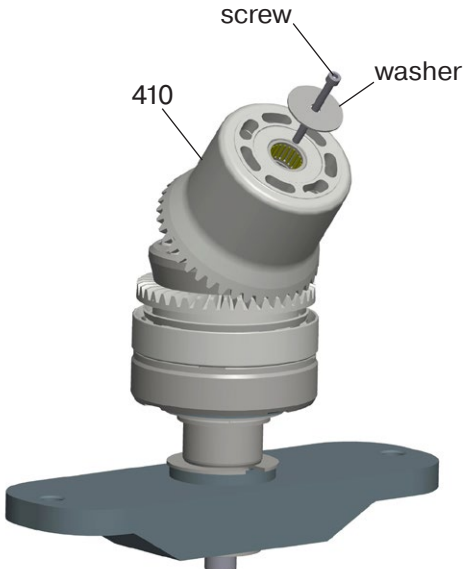

6. Remove screw and washer.
Disassemble the cylinder barrel (item 410), pistons (item 440) and barrel support (item 430).
See page 18 for item 440 and 430.

Disassembling

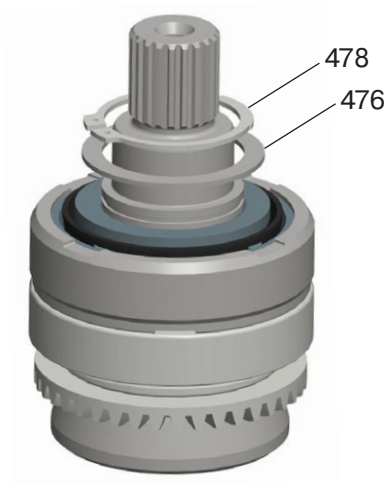

7. Disassemble the retaining ring (item 478) and the spacer washer (item 476).



8. Place the bearing package on a tube and disassemble the bearings by pressing on the shaft end.

Assembling

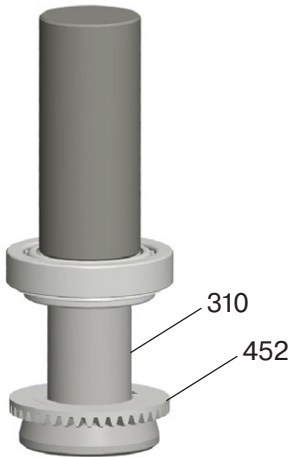

9. Place the ring gear (item 452) in correct position on the shaft (item 310). Place the tapered roller bearing (item 460) on the shaft. Press down the ring gear and tapered roller bearing by using a sleeve.

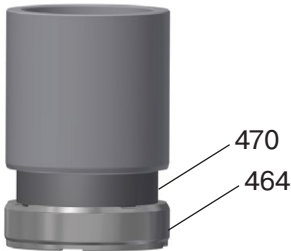

10. Press down the outer bearing racer (item 470) in to the spacer ring (item 464).



11. Place the spacer ring (item 464) and the tapered roller bearing (item 470) on the shaft. Press down the tapered roller bearing with a sleeve until correct preload is achieved. The rolling torque should be $11 \pm 1 \text{ Nm}$

Assembling

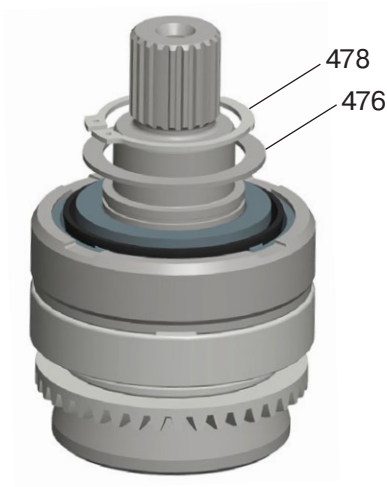

12. Assemble spacer washer (item 476) and retaining ring (item 478).

Note! The spacer washer should not be possible to move when retaining ring is assembled.

Choose a thicker spacer washer if it is possible to move it.

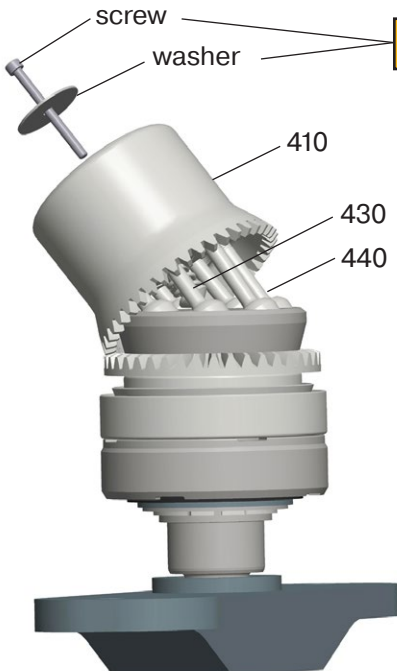

13. Assemble barrel support (item 430), pistons (item 440) and cylinder barrel (item 410).

Make sure the timing is correct (see picture 13).

Fasten screw and washer to secure that the cylinder barrel stays in correct position.

Assembling



14. Make sure the timing is correct.

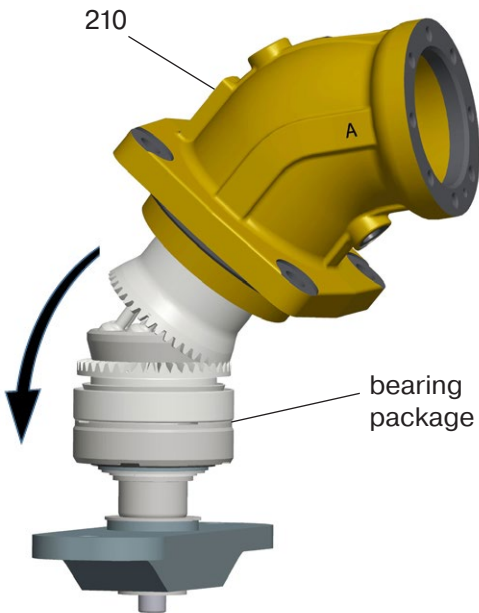
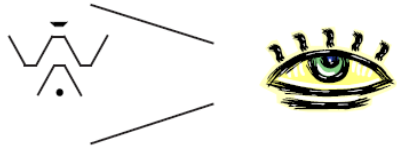

15. Carefully place the bearing housing (item 210) on the bearing package.

Note! This operation goes much smoother if the bearing housing is heated up to approximately 60°C.

Assembling

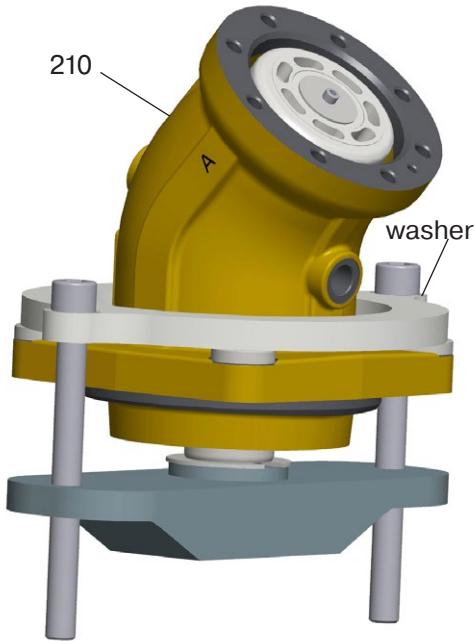

16. Assemble the bearing housing (item 210) by using the fixture as shown on the picture.

Turn the bolts alternately until the bearing housing is all the way down.

Note! This operation goes much smoother if the bearing housing is heated up to approximately 60 °C.

Secure that the the housing don't fall off when moving the motor. The grip could be loose due to the heated up housing.

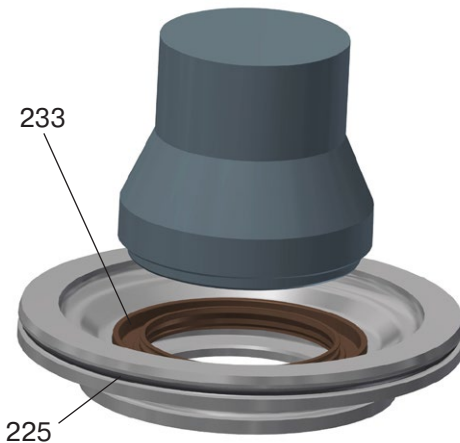

17. Assemble the shaft seal (item 233) and O-ring (item 225).

Note! Apply a thin layer of grease on the inner and outer diameter of the shaft seal before assembly.

Assembling

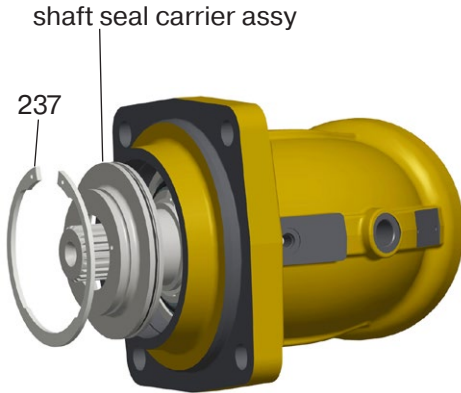

18. Assemble shaft seal carrier assy by using a tube. Carefully tap it in with a hammer.

Secure location by assembling the retaining ring (item 237).

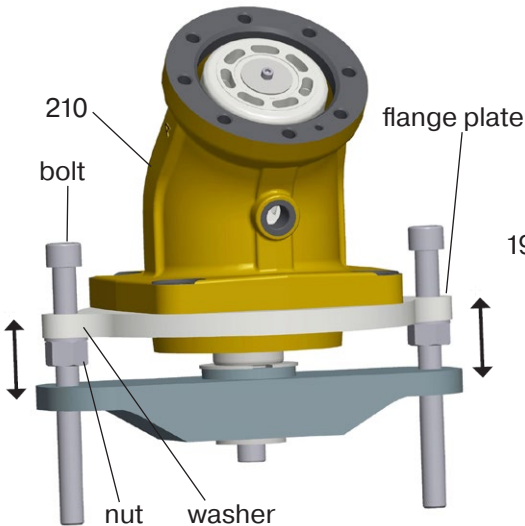

19. IMPORTANT !

Add the flange plate to the fixture with bolts, washers and nuts.

Turn the bolts alternately until the bearing housing (item 210) stops against the retaining ring (item 237), see picture 17.

Assembling



20. Make sure the timing is correct.
If the timing is wrong, release the screw slightly and set the timing to correct position again.

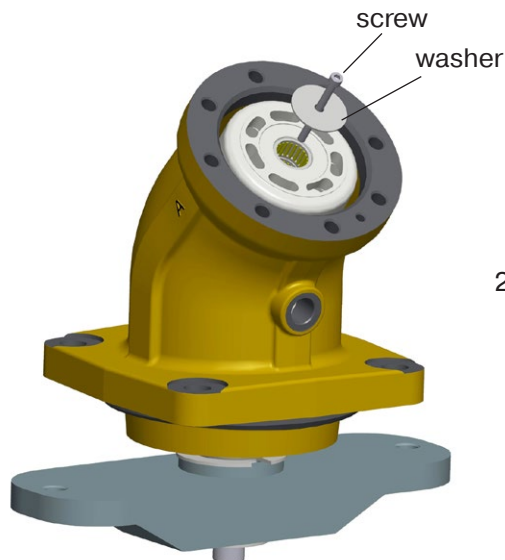
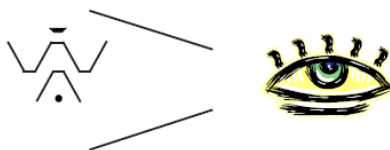

21. Remove screw and washer.

Assembling



22. Assemble the valve plate (item 121) in the end cap (item 110), use some grease to keep it in position. Place the O-ring (item 221) on the end cap (item 110).

Assemble the end cap with O-ring on the motor. Fit the bolts (item 491) and torque them to 180 ± 10 Nm.



23. Once again, make sure the timing is correct.

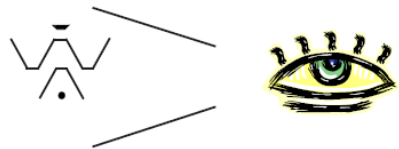

Assembling

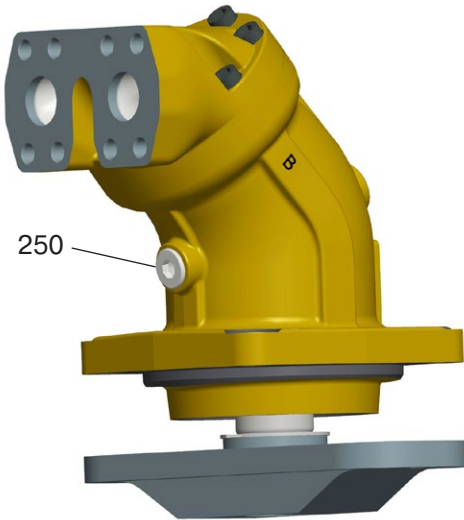

24. Assemble hexagon plug (item 250) according to customers specification.

Use a plier and turn the shaft at least one revolution and make sure it turns without problems.

Also make sure that there is back-lash.

Test Procedure

The general condition of the unit can be established by checking the drain flow. Remove the drain line and keep the drain port above a suitable container. Run the unit at 500 rpm and pressurise the system to 200 bar (3000 psi).

Measure the drain flow for one minute; if it exceeds the maximum figures shown below, the unit is worn or damaged internally and should be replaced or repaired. Also, check for leakage at the shaft seal and between the bearing and barrel housings.

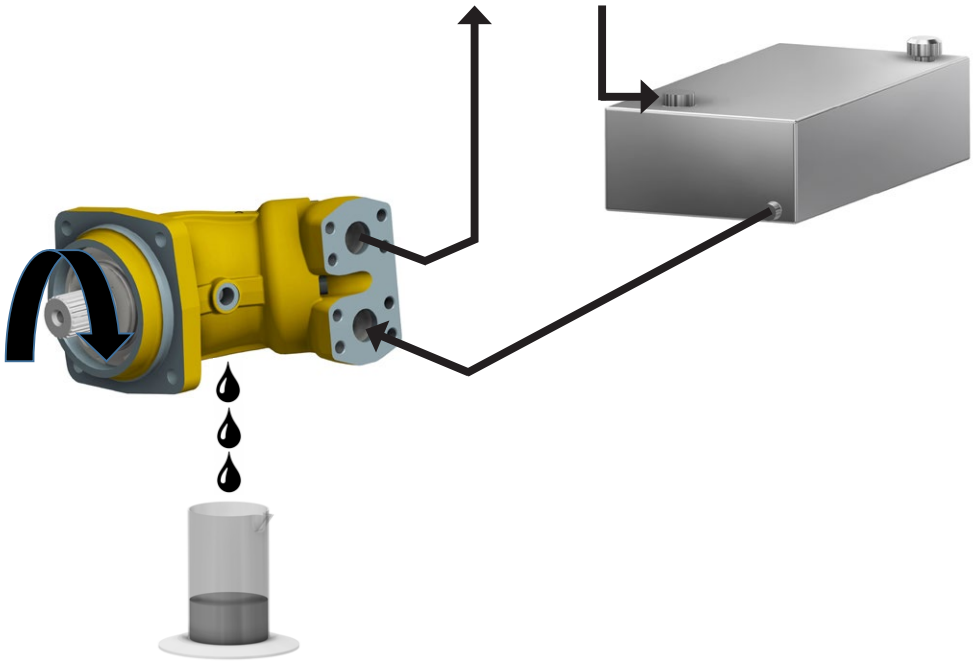

	(gpm, US)	(l/min)	(gpm, US)	(l/min)
F12-152	0.4	1.5	0.99	3.7
F12-162	0.43	1.6	1.08	4.1
F12-182	0.47	1.8	1.19	4.5

Splitview F12-152, -162, -182

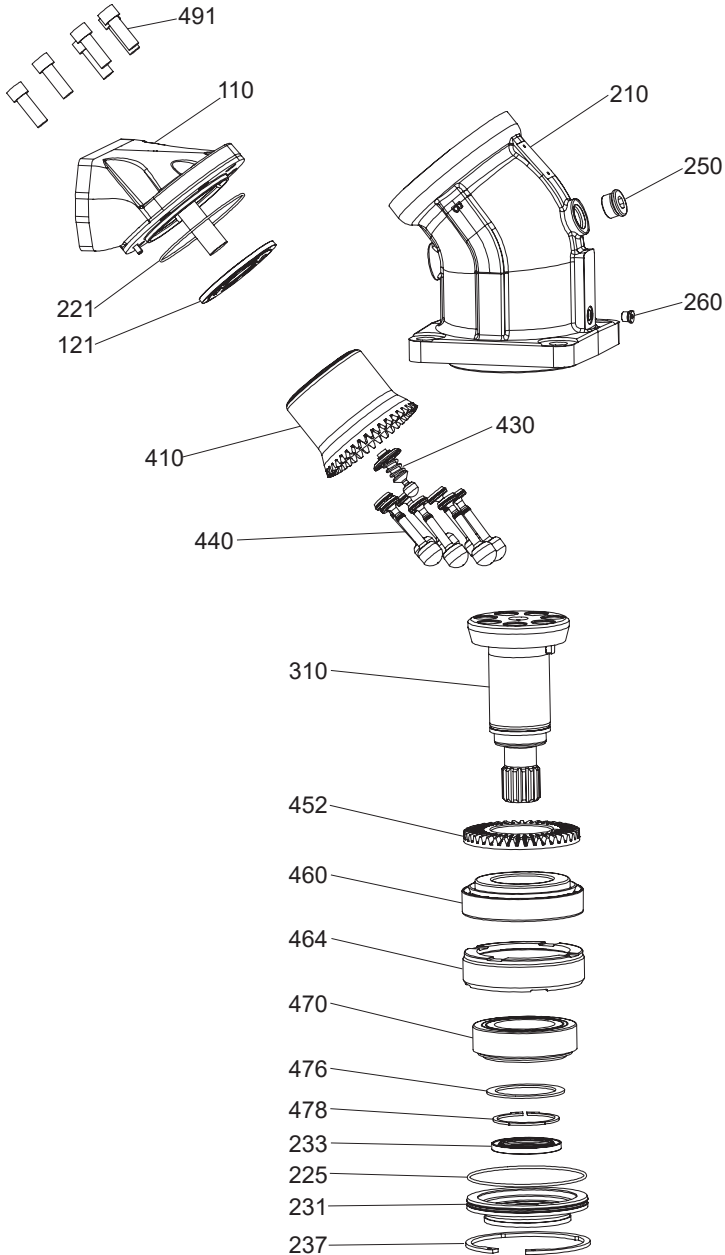

Parts specification

Item	Description
110	End Cap
121	Valve Plate
210	Bearing Housing
221	O-Ring 118*2,5 V80
225	O-Ring 132*3 V80
231	Seal Carrier
233	Shaft Seal 60*80*7
237	Retaining Ring SGH140
250	Hex Socket Plug Assy
260	Hex Socket Plug Assy
310	Shaft
410	Cylinder Barrel Assy
430	Barrel Support
440	Piston Assy
452	Ring Gear
460	Tap Roller Bearing
464	Spacer Ring
470	Tap Roller Bearing
476	Spacer Washer
478	Retaining Ring SGA70
491	Hex S Screw M14*40

Spare Parts for F12-152/162/182

Seal Kit

Items included 221, 225, 233, 237

<i>Product</i>	<i>Part No</i>
F12-152/162/182	3720863

Bearing Kit

Items included 460, 464, 470, 476, 478

<i>Product</i>	<i>Part No</i>
F12-152/162/182	3724011

Repair kit

Items included 121, 410, 440, 491

F12-152 Motor type M	3724007
F12-152 Motor type S	3724008
F12-182 Motor type M	3724009
F12-182 Motor type S	3724010
Other kit on request	

Shafts 152/162/182

Item 310

<i>Shaft</i>	<i>Part No</i>	<i>Key Part No</i>
Type K (key)	3720486	3724446*
Type G (key)	3784005	3724446*
Type D (spline)	3720490	
Type H (spline)	3720458	
Type T (key)	3784016	3724439*
Type S (spline)	3784010	
Type F (spline)	3720491	

* kit contain 100 pcs

Bearing housing 152/162/182

Item 210

Type I (ISO 180 mm)	3720766
Type F (ISO 200 mm)	3720765
Type S (SAE)	3720570

End Cap 152/162/182

Item 110

Type F 1 1/2" Vertical	3784018
Type D 1 1/4" Horizontal	3783958
Type K 1 1/4" Rear	3720302
Type M 1/1/4" Side	3720303

Tools

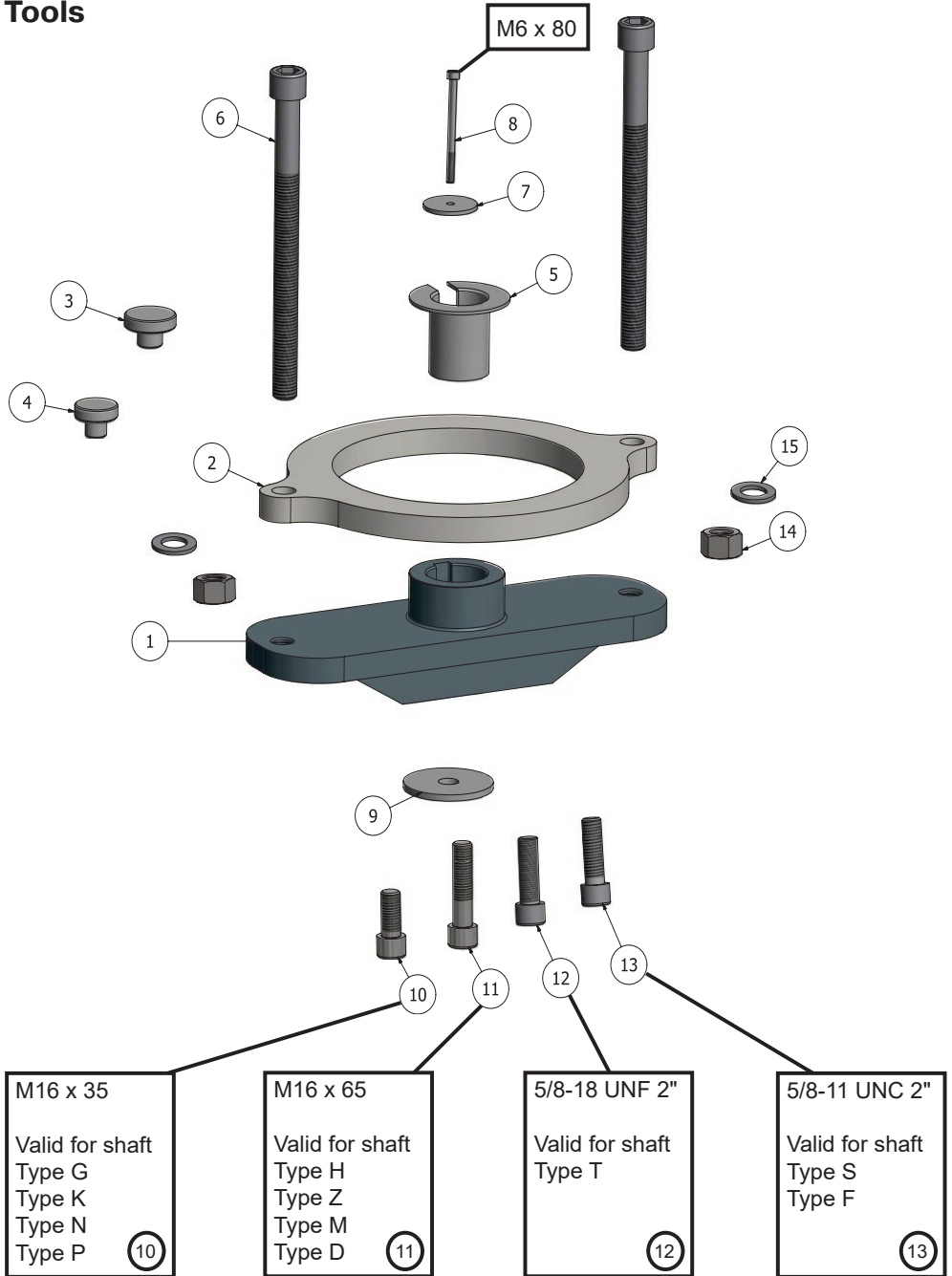

Position notification regarding Machinery Directive 2006/42/EC:

Products made by the Pump & Motor Division Europe (PMDE) of Parker Hannifin are excluded from the scope of the machinery directive following the "Cetop" Position Paper on the implementation of the Machinery Directive 2006/42/EC in the Fluid Power Industry.

All PMDE products are designed and manufactured considering the basic as well as the proven safety principles according to:

- ISO 13849-1:2015
- SS-EN ISO 4413:2010

so that the machines in which the products are incorporated meet the essential health and safety requirements.

Confirmations for components to be proven component, e. g. for validation of hydraulic systems, can only be provided after an analysis of the specific application, as the fact to be a proven component mainly depends on the specific application.

Christian Jäger

General Manger

Pump & Motor Division Europe

**WARNING – USER RESPONSIBILITY**

FAILURE OR IMPROPER SELECTION OR IMPROPER USE OF THE PRODUCTS DESCRIBED HEREIN OR RELATED ITEMS CAN CAUSE DEATH, PERSONAL INJURY AND PROPERTY DAMAGE.

This document and other information from Parker-Hannifin Corporation, its subsidiaries and authorized distributors provide product or system options for further investigation by users having technical expertise.

The user, through its own analysis and testing, is solely responsible for making the final selection of the system and components and assuring that all performance, endurance, maintenance, safety and warning requirements of the application are met. The user must analyze all aspects of the application, follow applicable industry standards, and follow the information concerning the product in the current product catalogue and in any other materials provided from Parker or its subsidiaries or authorized distributors.

To the extent that Parker or its subsidiaries or authorized distributors provide component or system options based upon data or specifications provided by the user, the user is responsible for determining that such data and specifications are suitable and sufficient for all applications and reasonably foreseeable uses of the components or systems.

Offer of Sale

Please contact your Parker representation for a detailed "Offer of Sale".

Parker Hannifin Manufacturing Sweden AB

Pump & Motor Division Europe

Flygmotorvägen 2

461 82 Trollhättan

Sweden

Tel. +46 (0)520 40 45 00

www.parker.com/pmde

MSG30-5520-M1/UK



© Copyright 2023
All rights reserved